

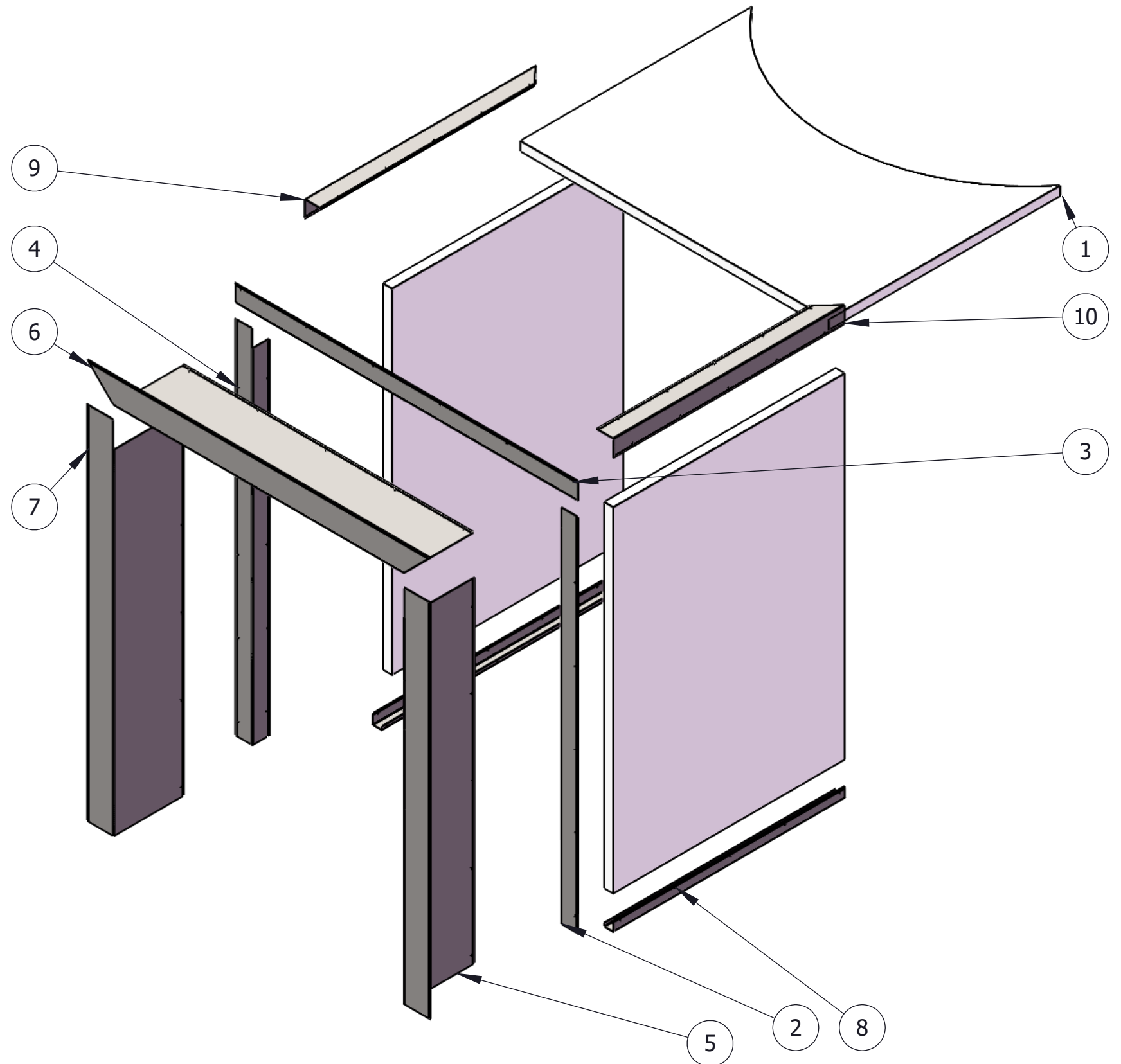

This document must not be copied without our written permission, and the contents thereof must not be imparted to a third party nor be used for any unauthorized purpose. Controvention will be prosecuted. Wedholms AB

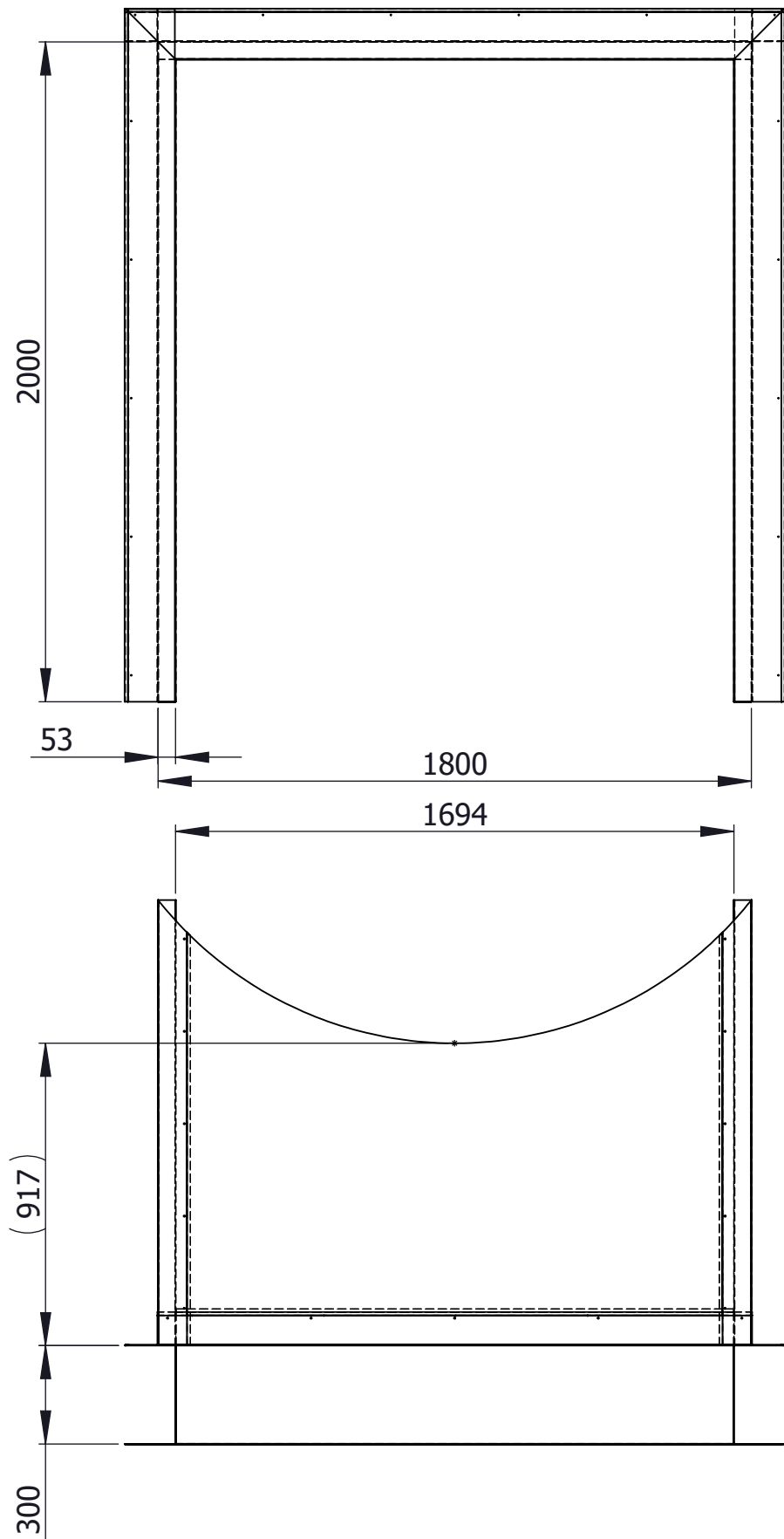

Drawn by PR	Date 2021-02-26	Approved by PR	√ indicates R <sub>a</sub> in μm		Scale 1:20	Tolerances for untoleranced dimensions acc. to ISO 2768-1-m	
TANK Full assembly alcov						Standard	
						Weight 419891.46	
		Reference number	Drawing number 1001362		Revision E		

This document must not be copied without our written permission, and the contents thereof must not be imparted to a third party nor be used for any unauthorized purpose. Controvention will be prosecuted. Wedholms AB

QTY.	POS	PART NUMBER	DESCRIPTION	DIMENSION	OPERATION
1	1	1001360	assembly of alcove Ø2300		
1	2	1000891	Right wall cover profile		
1	3	1000892	Roof cover profile		
1	4	1000893	Left wall cover profile		
1	5	1000894	Right inwall cover profile		
1	6	1000895	Roof inner cover profile		
1	7	1000896	Left inwall cover profile		
2	8	1001363	Floor bracket		
1	9	1001368	Left cover profile		
1	10	1001369	Right cover profile		

Drawn by PR	Date 2021-02-26	Approved by PR	<input checked="" type="checkbox"/> indicates $R_a$ in $\mu m$		Scale <b>1:20</b>	Tolerances for untoleranced dimensions acc. to ISO 2768-1-m	
<b>TANK</b> Full assembly alcov					Comments	Standard	
						Weight	
 Wedholms AB		Reference number	Drawing number <b>1001362</b>		Revision <b>E</b>		